

ON-GOING MAINTENANCE

To prevent the build up of limescale and water impurities, especially in hard water areas, it is recommended to follow these procedures:

- 1) On a monthly basis the thermostatic control handle should be rotated between the maximum and minimum limits by pressing the override button and with the water running.
- 2) Should the thermostatic cartridge not function properly the most likely cause is the build up of limescale/ water impurities.

CLEANING OF FILTERS:

The thermostatic mixer is provided with a filtering facility, preventing foreign particles to enter. Filters are fitted on water inlets. According to water quality and composition, filters may become dirty causing reduced flow and inefficient working of the mixer

To clean filters on inlets just follow these instructions (picture A)

1. Shut off water supply to both inlets
2. Unscrew the mixer from pipeworks by using a 30mm wrench
3. Remove the filters (1) from union nuts (2)
4. Clean filters with water. In case of limescale build up, leave to soak in vinegar overnight, then rinse with water
5. Insert filters into union nuts and re-assemble the mixer on pipeworks
6. Turn on water supply.

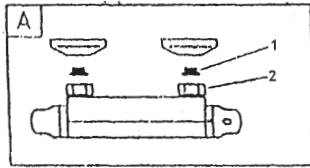

IN CASE OF LEAKAGE

If water leaks out from the mixer even when the handle is in "OFF" position, that means that the ceramic cartridge has to be replaced. Proceed as follows:

1. Shut off water supply to both inlets
2. Remove the screw cover (1) unscrew the fixing screw (2) and remove the handle (3)
3. With a 17mm wrench, unscrew and remove the ceramic cartridge (4)

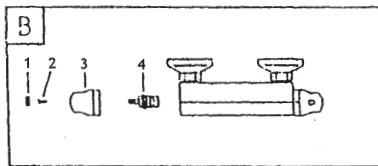

GENERAL CLEANING

1. We recommend that Cifial products are cleaned using a **soft damp cloth**, we strongly advise against using any cleaning products, either powders or liquids, as they may contain harmful chemicals which may damage the product.
2. Shower heads need to be regularly "rubbed" to prevent the build up of limescale on the outlet nozzles.

CIFIAL

IMPORTANT
care and maintenance



Exposed Thermostatic Shower Valve

Please leave this booklet
with the customer
for future use

INSTALLATION & OPERATING INSTRUCTIONS

HOT WATER SUPPLY

This mixer is suitable for any water heating system. In case of instantaneous heaters, hot water flow has to meet at least the minimum flow required by the heater to start and go on burning (this minimum flow is specified by heater's manufacturer) Instantaneous heaters of power equal or higher than 18KW or 250 mth/min are suitable. Generally, instantaneous water heaters having a lower power may not be suitable to work properly with any thermostatic mixer.

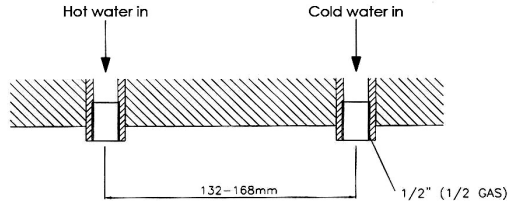

OPERATING SPECIFICATIONS

Hot water supply temperature:

maximum: 85°C

minimum: 10°C higher than maximum required mixed temperature from mixer

advisable: 65°C

minimum difference between hot in and mixed out temperature is 10°C

Operating Pressure:

maximum: 5 bar

minimum: 1 bar

recommended: 2 bar

Operating pressures (on hot and cold line) should be kept as balanced as possible in order to assure the maximum efficiency of the mixer.

When pressure is higher than 5 bar a pressure reducer is required.

INSTALLATION:

1. **IMPORTANT:** Rinse pipeworks carefully for a long while before fitting the mixer. Do not allow dirt, metal particles, shavings to block filters fitted on inlets. In that case you will be required to remove and clean dirty filters.
2. After having rinsed pipeworks, install the mixer as a standard exposed fitting with water outlet downwards and temperature control handle at the right. Centre measurements between the water inlets of this mixer is 150mm according to standards. However, you can have the flexibility to install between 132mm and 168mm centres by using the excenter unions provided (1/2" male thread)

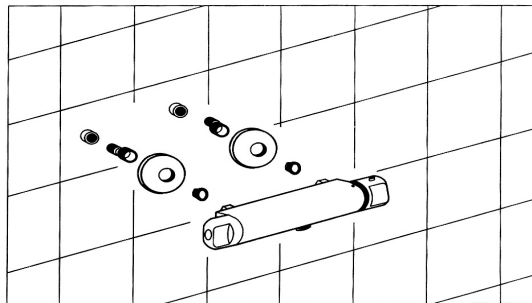

INSTALLATION & OPERATING INSTRUCTIONS cont

3. Connect hot supply to left inlet of the mixer and cold supply to right inlet
4.
 - Mount excenter unions (1) on supply pipes
 - Apply covering rosettes (2) on the 3/4" GAS threaded side of excenter unions
 - Set the excenter so that they correspond to mixer's inlets
 - Insert the delivered filter-gaskets (3) into both union nuts (4); then fix the mixer to the excenter unions by tightening nuts alternatively with a 30mm wrench
 - Turn on water supply and check the sealing of your installation

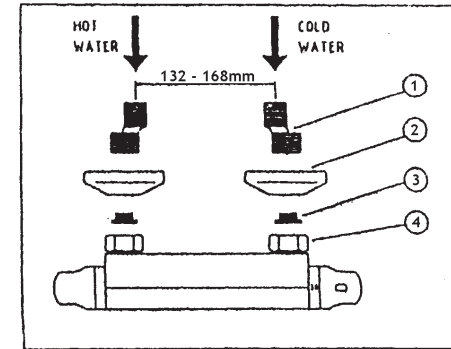

TEMPERATURE SETTING (to be done only when necessary)

This mixer has been set in the factory under balanced pressures and hot water supply at 65°C. When your own operating conditions are too different from the above temperature of the mixed water may vary from the setting. When difference is too great you can adjust the calibrations of the mixer to suit the individual requirements of your own installation.

Follow carefully these instructions:

1. Select 38°C temperature on control handle and check with a thermometer what is the temperature of the water being delivered from the mixer (picture A)
2. When finding unacceptable difference between selected temperature and the one really supplied by the mixer proceed to reset the calibrations as follows:
3. Without moving the handle, remove the screw cover (1) on the top of it, then unscrew the fixing screw (2) - picture B
4. Now remove the handle (3). do not move the white plastic ring (4). Then, while keeping pressed the red button, replace the handle so that the temperature you have just measured corresponds to the dot on the body of the mixer (picture C)
5. Mixer's setting is now calibrated according to your own individual requirements.

A

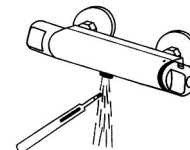

B

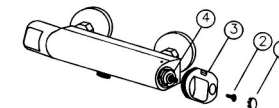

C

