

TECHNICAL SPECIFICATIONS

- Valve type : 1/2" ceramic disc valve 3/4 turn tested to 500,000 cycles.

- PRESSURE

Minimum working pressure	0,2 bar
Recommended working pressure	1 - 5 bar
Maximum working pressure	10 bar
Test pressure	16 bar

WHERE INLET PRESSURE EXCEEDS
5 bar FIT PRESSURE REDUCING VALVE

These valves are designed to work on balanced pressure supplies and are suitable for use with tank feed supplies, combination Boiler/Multipoint supplies or supplies from direct mains feed systems.

Subject to minimum/maximum pressure requirements as above

- TEMPERATURE

Minimum working temperature	1°C
Maximum (at hot water inlet)	85°C
Recommended temperature range	5°C - 60°C

- FLOW RATE

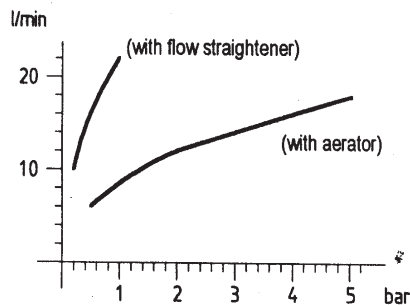

IF THE PRESSURE IS HIGHER THAN 1 bar
REMOVE FLOW STRAIGHTENER AND REPLACE
WITH AERATOR PROVIDED

To exchange aerator/ flow straightener unscrew the housing (16.1) from the spout, change the innerpart (flow straightener)(16.2) by the aerator supplied and re-assemble ensuring that washer (16.3) is in the correct position.

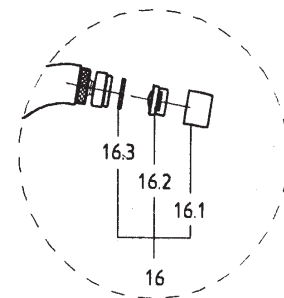
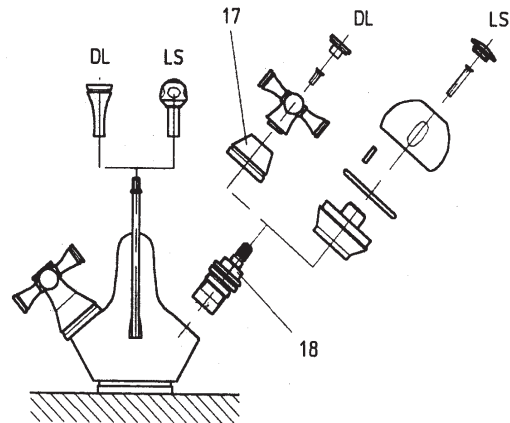
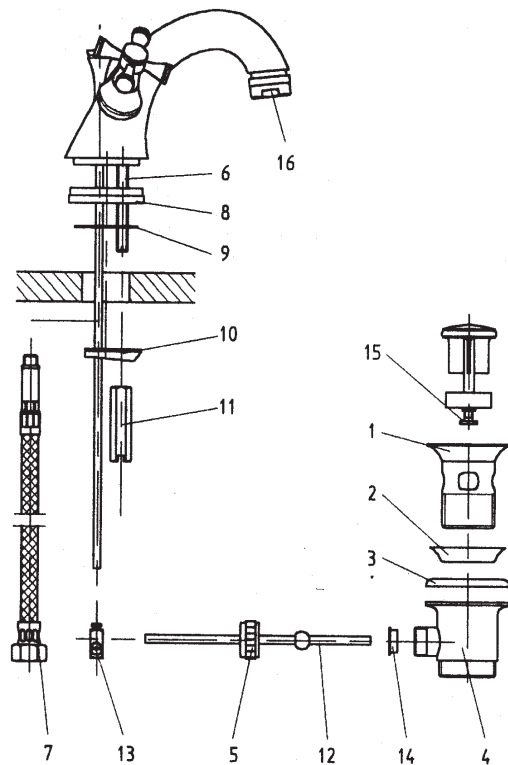

installation

1. Ensure that supply requirements with regard to pressure and temperature are complied with. (See technical specifications)
2. Fit top half of pop up waste section (1) through basin, fitted with cone shaped sealing washer supplied (2), or sealed with silicone if appropriate. Seat round rubber washer (3) to bottom half of pop up waste section (4) and screw firmly to top half (now projecting through basin waste hole), ensuring on completion that the connection for horizontal pop up rod is facing directly below basin taphole.
3. Screw stud bar section (6) into base of mixer and flexible connectors (7) into hot & cold inlet ports on base of mixer ensuring that O-ring seat firmly. Fit base shroud (8) and rubber seal (9) over these and locate mixer tap into basin taphole.
4. Slide horseshoe brass plate (10) over stud bar section and around flexible tails and screw firmly into place with long hexagonal nut (11). Your basin mixer should now be secure and stable. If mixer moves slightly without excessive force, tighten hexagonal nut a little more.
5. Fit ball end of horizontal pop up rod (12) into connection point on bottom section of pop up waste fitting with seal (14) provided and tighten capnut (5) by hand as tight as possible. Fit link piece (13) to vertical and horizontal pop up rods and tighten screws to both rods. Adjust pop up plug screw section (15) to required length, ensuring that the plug seats properly into waste fitting when plug is down but that plug lifts clear of waste when pop up knob on mixer is depressed, then tighten locking nut firmly. If plug reseats itself into waste when pop up knob on the mixer is released, tighten capnut (5) on bottom section of waste fitting further.

YOUR MIXER IS NOW READY FOR PLUMBING CONNECTIONS

6. Fit 3/8" MBSP connectors (Not Supplied) to ends of copper tube then to female swivel ends of flexible tails with fibre, rubber or PTFE washers.

Please Note: Hot on left and Cold on right when viewed from the front of the mixer

7. Fit 1.1/4" waste trap to bottom section of waste assembly and to waste discharge pipe.
8. Remove aerator or straightener (16) before opening isolation valves to test supplies and flush pipework. Check both supply and waste connections for leakage and flush through thoroughly to remove any sediment from the system. Refit aerator or flow straightener.

maintenance

1. Cleaning:
Clean the product with warm soapy water and a soft cloth. Light deposits of scale can be removed by washing with a diluted solution of vinegar and water and rinsing with tepid clean water and drying with a soft cloth.

Never use acid or abrasive cleaning materials.

Periodically the aerator in the mixer spout should be cleaned to remove deposits of scale. Unscrew the aerator (16) from the spout and dismantle. Open the cold tap and rinse the pieces of the aerator under the running water, using a soft brush if necessary then re-assemble and re-fit the aerator.

Do not clean any plastic pieces with products containing alcohol, acetone or any disinfectants.

2. Valve Maintenance:
Turn off hot and cold water supply. Check it is off by opening the mixer.
To access the valve body, pull up and off the decorative piece of the tap handwheel, or unscrew the cross-handle cover. Remove the now exposed screw thereby enabling removal of the main section of the handwheel. Unscrew the valve cover (17). Unscrew the large hexagon section of the valve body (18) from the tap body. Flush through thoroughly and re-fit, **do not** disassemble the valve. For further information contact Cifial (UK).

3. Finish Protection:
If the mixer is fitted in an area not frequently used, ensure that evaporation does not cause the water level in the trap to diminish as the fumes from the drain can be harmful to plated finishes, simply run the tap once a week for a few seconds.