



Euro Exposed Thermostatic Shower Valve

INSTALLATION AND MAINTENANCE INSTRUCTIONS

GUARANTEE

This product is covered by guarantee for one year from date of purchase.
Chrome plating is covered by guarantee for five years.

The guarantee does not cover faults or damages caused by incorrect installation and/or maintenance, ordinary wear and tear, water composition, i.e.:

- Incorrect installation, inversion of supply pipes;
- Pressures or temperatures exceeding specified limits;
- Improper manipulation, tampering, incorrect or missed maintenance;
- Foreign bodies and/or scale brought by water, ice, ordinary wear, water composition;
- Use of improper cleaning or maintenance products or substances.

To end-user:

Please do not throw this Instructions Notice away. Keep it as a maintenance guide for keeping your mixer as efficient as it is now.

EXPOSED THERMOSTATIC MIXER

HOT WATER SUPPLY

This mixer is suitable for any water heating system.

In case of instantaneous heaters, hot water flow has to meet at least the minimum flow required by the heater to start and go on burning (this minimum flow is specified by heater's manufacturer)

Instantaneous heaters of power equal or higher than 18 KW or 250 mth/min are suitable.

Generally, instantaneous water heaters having a lower power may not be suitable to work properly with any thermostatic mixer.

OPERATING SPECIFICATIONS

Hot Water Supply Temperature:

maximum: 85°C

minimum: 10°C higher than maximum required mixed temperature from mixer

advisable: 65°C

Minimum difference between hot in and mixed out temperature is 10°C.

Operating Pressure:

maximum: 5 bar

minimum: 1 bar

recommended: 2 bar

Operating pressures (on hot and cold line) should be kept as balanced as possible, in order to assure the maximum efficiency of the mixer.

When pressure is higher than 5 bar a pressure reducer is required, to be fitted before the mixer.

INSTALLATION

1. **IMPORTANT:** Rinse pipeworks carefully for a long while before fitting the mixer: do not allow dirt, metal particles, shavings to block filters fitted on inlets.
In that case you will be obliged to remove and clean dirty filters.
2. After having rinsed pipeworks, install the mixer as a standard exposed fitting, with water outlet downwards and temperature control handle at the right.
Centremasurement between the water inlets of this mixer is 150mm, according to standards.
However you can have the flexibility to install between 132mm and 168mm centres, by using the excenter unions provided (1/2" GAS male threaded)

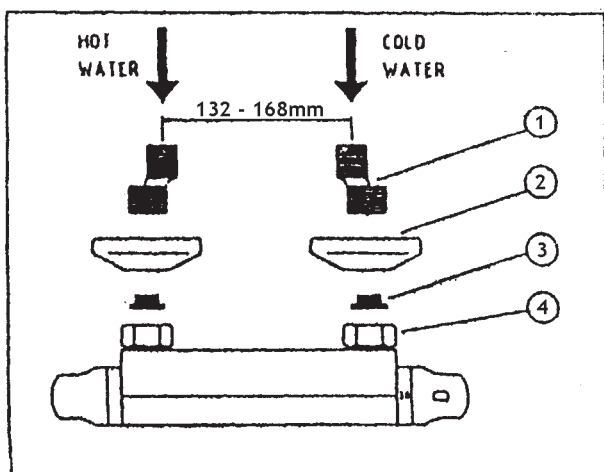

3. Connect hot supply to left inlet of the mixer (part marked with a red dot) and cold supply to right inlet (part marked with a blue dot).
4.
 - Mount excenter unions (1) on supply pipes;
 - Apply covering rosettes (2) on the 3/4" GAS threaded side of excenter unions;
 - Set the excenter so that they correspond to mixer's inlets;
 - Insert the delivered filter-gaskets (3) into both union nuts (4); then fix the mixer to the excenter unions, by tightening nuts alternatively with a 30mm wrench.
 - Turn on water supply and check the sealing of ur installation.

TEMPERATURE SETTING (to be done only when necessary)

This mixer has been set in factory under balanced pressures and hot water supply at 65°C. When your own operating conditions are too different from the above, temperature of the mixed water may vary from the setting. When difference is too great you can adjust the calibration of the mixer to suit the individual requirements of your own installation.

Follow carefully these instructions:

1. Select 38°C temperature on control handle, and check with a thermometre what is the temperature of water being delivered from the mixer (picture A)
2. When finding unacceptable difference between selected temperature and the one really supplied by the mixer, proceed to reset the calibration as follows:
3. Without moving the handle, remove the screw cover (1) on the top of it, then unscrew the fixing screw (2) - (picture B).
4. Now remove the handle (3). Do not move the white plastic ring (4). Then, while keeping pressed the red button, replace the handle so that the temperature you have just measured corresponds to the dot on the body of the mixer (picture C).
5. Mixer's setting is now calibrated according to your own individual requirements.
6. Fix the handle with the screw and put on the screw cover.

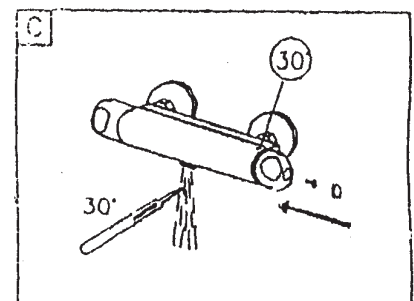
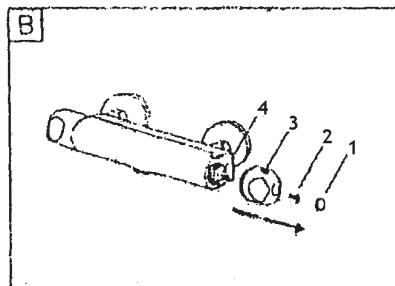
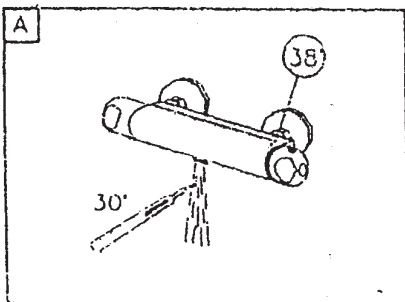

MAINTENANCE

Cleaning of filters

The thermostatic mixer is provided with a filtering facility, preventing foreign particles to enter. Filters are fitted on water inlets.

According to water quality and composition, filters may become dirty, causing reduced flow and inefficient working of the mixer.

To clean filters on inlets, just follow these instructions (picture A):

1. Shut off water supply to both inlets.
2. Unscrew the mixer from pipeworks, by using a 30mm wrench.
3. Remove the filters (1) from union nuts (2).
4. Clean filters with water. In case of scale, leave to soak in vinegar or a descaling solution, then rinse with water.
5. Insert filters into union nuts and reassemble the mixer on pipeworks
6. Turn on water supply and check the sealing of your installation.

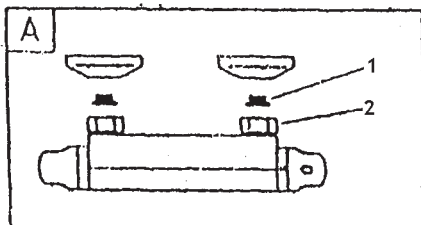

In case of leakage

If water pours out from the mixer even when the handle is in "OFF" position, that means that the open/close headwork has to be replaced. Proceed as follows:

1. Shut off water supply to both inlets.
2. Remove the screw cover (1), unscrew the fixing screw (2) and remove the handle (3).
3. With a 17mm wrench, unscrew and remove the headwork (4).
4. Show your supplier the old headwork and ask for a new one of the same kind.

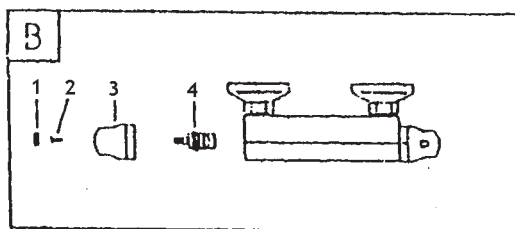

SURFACE CLEANING

For surface cleaning of the mixer use water and soap only, and dry with a soft cloth.

Any other cleaning product may damage the surface, and will render the guarantee invalid.

NON-COMPLIANCE WITH THE ABOVE INSTRUCTIONS WILL RENDER THE GUARANTEE INVALID