

# TECHNO 35

## Thermostatic Fixed/Flexi Shower Kit



*Pack consists of:*

*1 x 600V32SE Thermostatic Shower valve  
made up of:  
1 x 35830SE Trim Set  
1 x 3580017 Valve Rough*

*1 x 080 Fresco shower handset  
1 x 048 Shower Hose  
1 x 3450220 Technovation Wall Outlet  
1 x 34501TH Technovation Slider Bar*

*1 x 227 Ultra Slim 200mm Fixed Head  
1 x 046 wall arm 300mm*

## Style 35 / Technovation 35

**Termostática embutida 3 furos - 2 saídas**  
**Concealed Thermostatic 3 holes - 2 outlet**

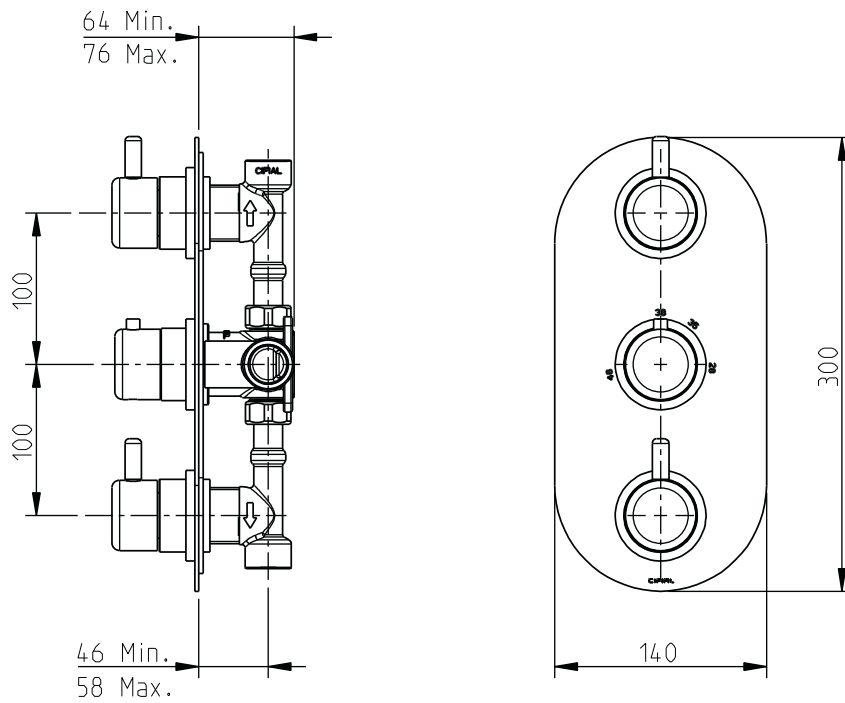

3580017

Válvula Termostática Embutida 2 Furos - 1 Vias  
Concealed Thermostatic Valve 2 Holes - 1 Outlet  
Vendido Separadamente / Sold Separately

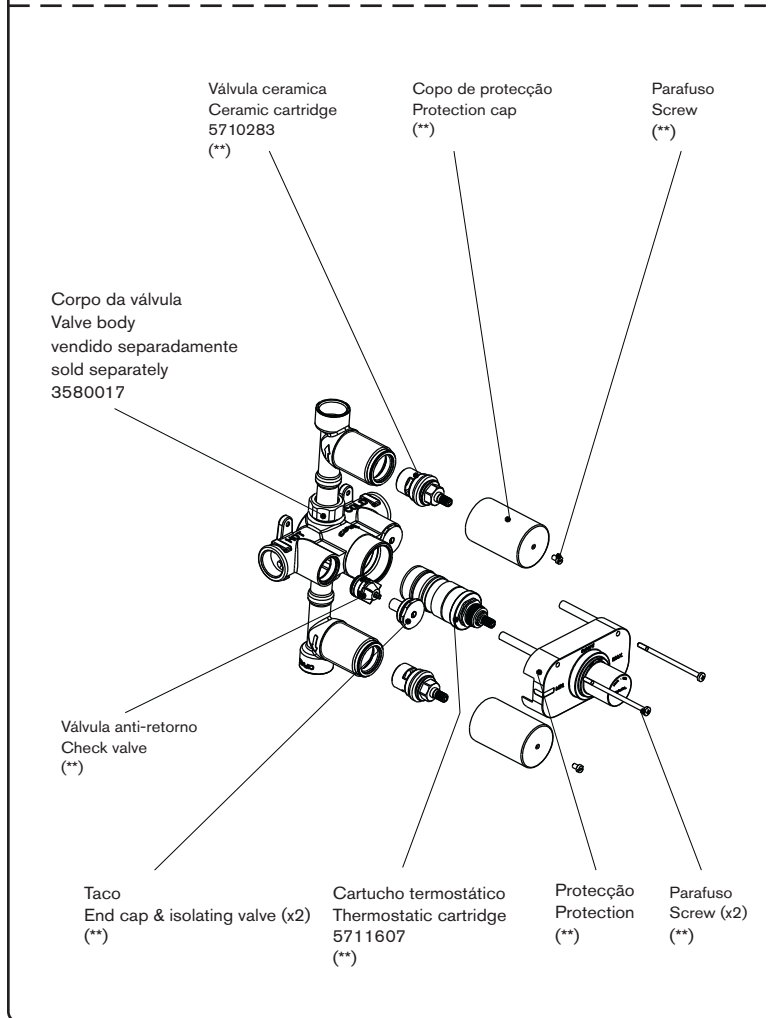

**Notas / Notes:**

- 1) Na instalação, alinhar o ponto vermelho do anel limitador de temperatura com o número 38 impresso no espelho.  
The red dot on the temperature limit ring must be aligned with the number 38 on the back plate.
- 2) xxx indica o código do acabamento.  
xxx represent different finishes.
- 3) (\*\*) conjunto pré-montado de fábrica 3580017.  
(\*\*) kit 3580017 pre-assembled at factory.

Instalador: Por favor entregue todas as instruções que acompanham este produto ao seu proprietário.

Installer: Please leave all leaflets with the building owner to file for future reference

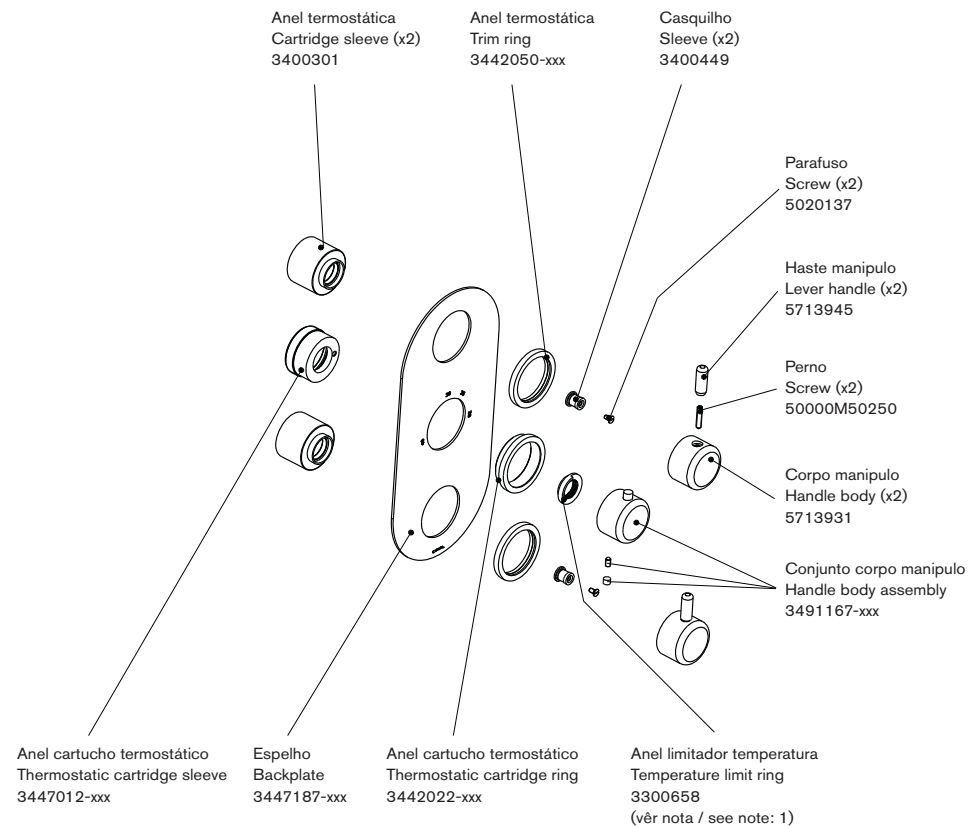

# PT

## Operação

O manípulo superior abre, fecha e regula o caudal da água. O manípulo inferior controla a temperatura da água. A temperatura da água considerada confortável está entre os 32°C e 38°C, mas a possibilidade de regulação vai dos 28°C até aos 48°C.

O anel limitador de temperatura evita queimaduras acidentais não permitindo que o manípulo seja rodado para além dos 38°C. No caso de se pretender ultrapassar aquela temperatura, deve premir-se o botão e rodar o manípulo no sentido contrário dos ponteiros do relógio. Para prevenir queimaduras, deve assegurar-se que o manípulo seja recolocado numa posição anterior ao batente de segurança (= ou <38°C).

## Antes de usar - Regulação da temperatura

1. Remover o manípulo de regulação de temperatura.
2. Confirmar se o anel limitador de temperatura na haste da válvula termostática apresenta a marca vermelha coincidente com a marca 38°C gravada no espelho; se não estiver corrigir a posição.
3. Abrir o manípulo de regulação de caudal, deixar a água correr, e verificar com a ajuda de um termómetro a temperatura da água. Aquando da calibração, é aconselhável a escolha de uma temperatura que ronde os 38°C. Para o conseguir, rodar a haste da válvula termostática no sentido dos ponteiros do relógio para aumentar a temperatura ou vice versa. Para rodar a haste, pode utilizar o manípulo termostático carregando no botão, se necessário.
4. Estando a temperatura a 38°C aplicar o manípulo no sistema alinhando o botão com a marcação 38°C.
5. A válvula termostática fica assim calibrada, conforme os seus próprios requisitos de funcionamento.
6. Aperte o manípulo termostático com o parafuso respectivo.

**nota:** Recomendamos que regularmente se rode o manípulo de regulação de temperatura entre os limites máximo e mínimo, premindo o botão de segurança e com a misturadora aberta. Desta forma evitam-se incrustações de calcário que podem bloquear o cartucho termostático.

# EN

## Operation

The upper handle turns on and off the water and controls the flow rate. The lower handle controls only the water temperature. The comfort zone is in the range from 32°C to 38°C, but total range is 28°C to 48°C. Protection against scalding stops the rotation of the handle at 38°C. If water above 38°C is desired, press on the button and turn the knob counterclockwise, to prevent scalding, ensure that the handle is left in a previous position (= or <38°C).

## Prior to use - Setting the temperature

1. With the stop valve (flow control) in the off position, remove the thermostatic valve handle and the temperature limit ring.
2. Put back on the thermostatic valve handle and turn clockwise until the cartridge "clicks". This is now set at fully cold.
3. Turn on stop valve and turn the thermostatic valve handle anti-clockwise until the desired temperature is reached, ie 38°C. Use a thermometer to check if the temperature is correct.
4. Turn off the stop valve, remove the thermostatic valve handle and replace the temperature limit ring with the red dot in the 12 o'clock position, ie corresponding with the 38°C on the etched plate.
5. Replace the thermostatic valve handle with the temperature override button position just prior to the 38°C.
6. Your thermostatic valve is now ready for use.

**note:** It's recommended that you rotate the thermostatic control handle between the maximum and minimum limits, by pressing security button, and with the water running. This way you prevent limestone incrustation, that could block up the thermostatic cartridge.

2. Marca vermelha orientada para os 38°C  
Red mark aligned to the mark 38°C

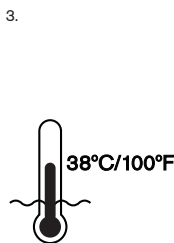
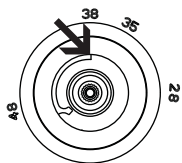

4. Botão limitador contra-queimaduras  
Anti-scalding button

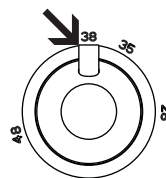

www.cifial.pt | cifial@cifial.pt  
www.cifial.es | cifial@cifial.es  
www.cifial.co.uk | sales@cifial.co.uk  
www.cifialusa.com  
www.cifial.pl | cifial@cifial.pl

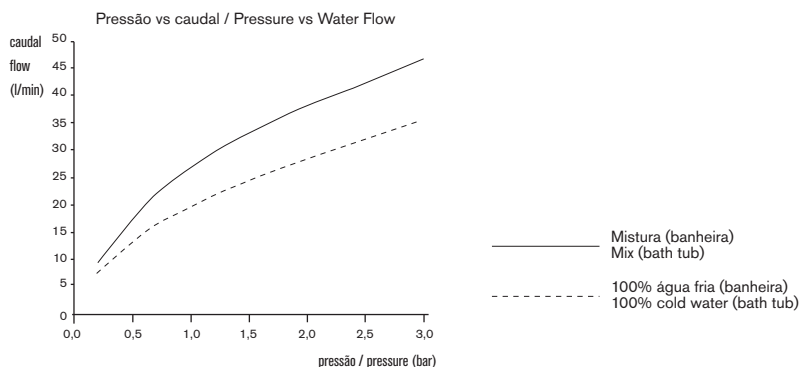

# FRESCO

## Flexi Shower Handset

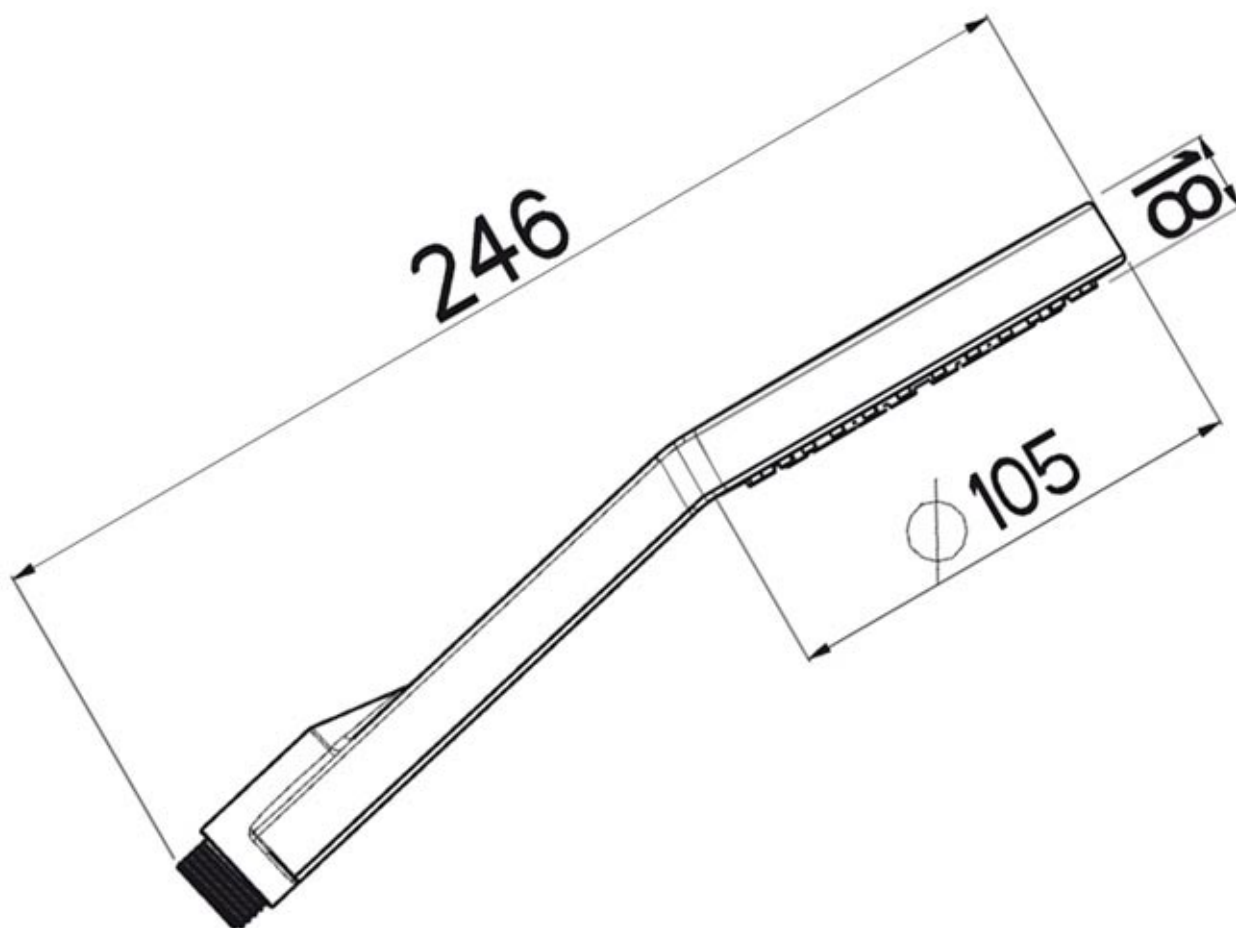

# TECHNOVATION

## Wall Outlet

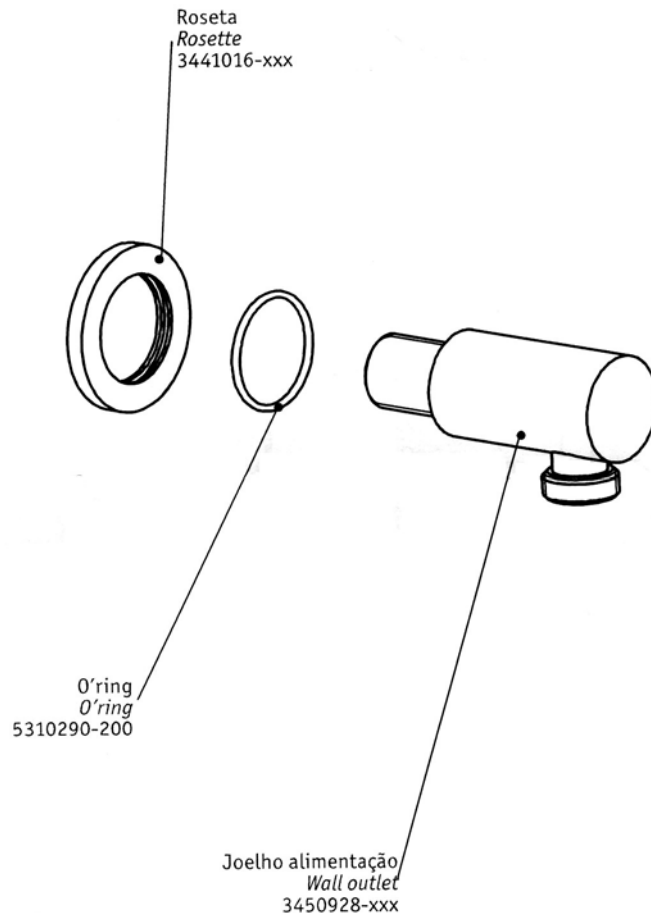
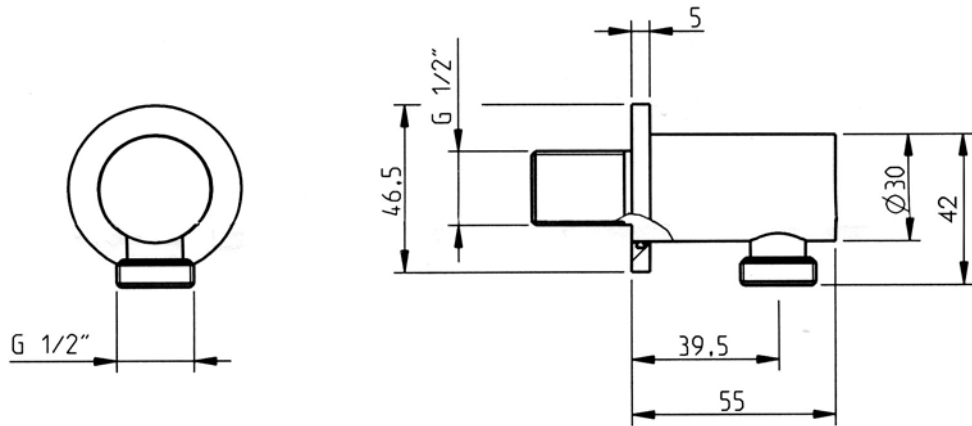

# INSTRUÇÕES DE INSTALAÇÃO INSTALLATION INSTRUCTIONS

## Techno / Technovation

Barra de chuveiro / Shower slider bar

código/code | 34500TH-xxx  
34501TH-xxx  
34502TH-xxx (UK)

**INSTALADOR / INSTALLER:**  
Por favor entregue todas as instruções que acompanham este produto ao seu proprietário.  
Please leave all leaflets with the building owner to file for future reference.

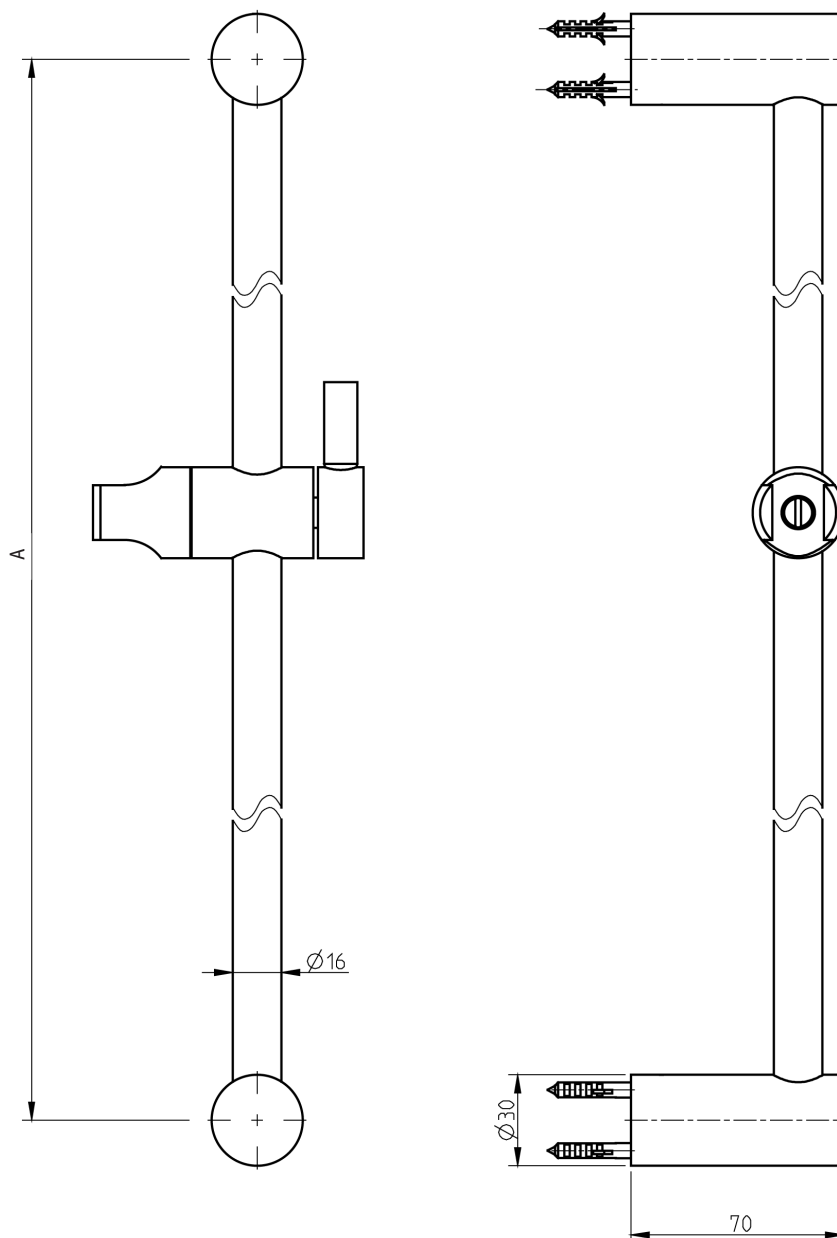

Código/Code	Descrição/Description	A
34500TH-xxx	Barra chuveiro 900 / Shower slider bar 900	883
34501TH xxx	Barra chuveiro 600 / Shower slider bar 600	583
34502TH-xxx	Barra chuveiro 600 / Shower slider bar 600	583

5663406  
983TH019D02

dimensões mm/dimensions mm

## TORNEIRAS / PLUMBING

**CIFIAL Torneiras, S.A.**  
Portugal T +351 256 780 700 F +351 256 780 710 [cifial@cifial.pt](mailto:cifial@cifial.pt) [www.cifial.pt](http://www.cifial.pt)  
**CIFIALDECOR, S.A.**  
Espanha T +34 916 110 261 F +34 916 103 694 [cifialdecor@infonegocio.com](mailto:cifialdecor@infonegocio.com)  
**CIFIAL UK, Ltd.**  
UK P +44 1933 402 008 F +44 1933 402 063 [sales@cifial.co.uk](mailto:sales@cifial.co.uk) [www.cifial.co.uk](http://www.cifial.co.uk)  
**CIFIAL USA**  
USA P +1800 5284904 F +1800 5281969 [info@cifialusa.com](mailto:info@cifialusa.com) [www.cifialusa.com](http://www.cifialusa.com)

# CIFIAL

Nº	Descrição/Description	Q
1	Bucha Raw plug	4
2	Casquilho Sleeve	1
3	Corpo central barra de chuveiro Adjustable handset holder	1
4	Fixador Wall bracket	2
5	Parafuso Screw	4
6	Poste Post	2
7	Perno Grub screw	2
8	Tubo Slider bar	1

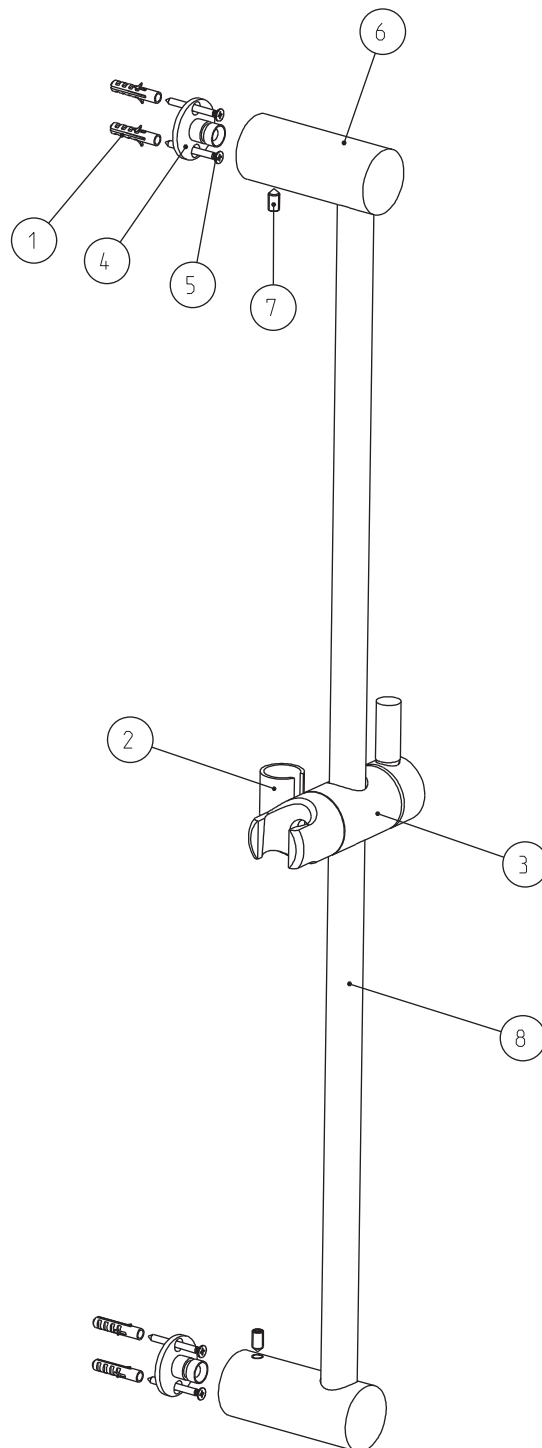



# ULTRA SLIM Round 200mm

Head including swivel ball joint

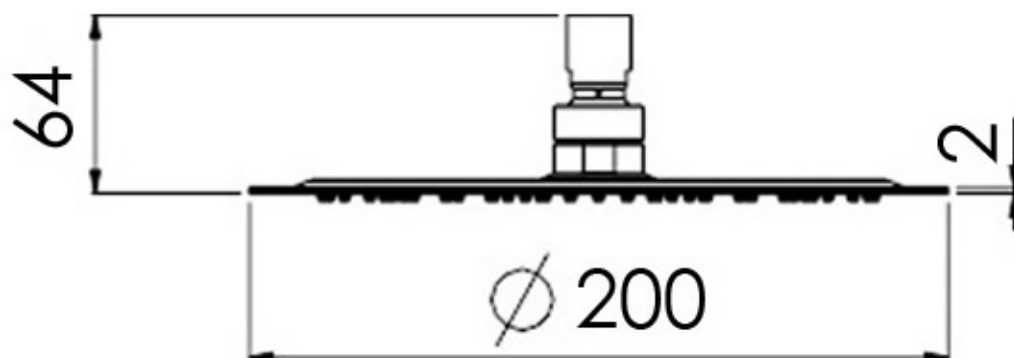

# 300mm Fixed Wall Arm

---

